



WaterMaster®

Installation Manual / User's Manual

Sprinkler Timers by Orbit®

Manuel d'installation / Manuel d'utilisation

Programmateurs d'arrosage par Orbit®

Manual de Instalación / Manual del usuario

Programadores para sistemas de aspersión Orbit®

Manuale d'installazione / Manuale d'uso

Programmatore per irrigazione Orbit®

Installationshandbuch / Benutzerhandbuch

Orbit® Steuergerät für Bewässerungssysteme

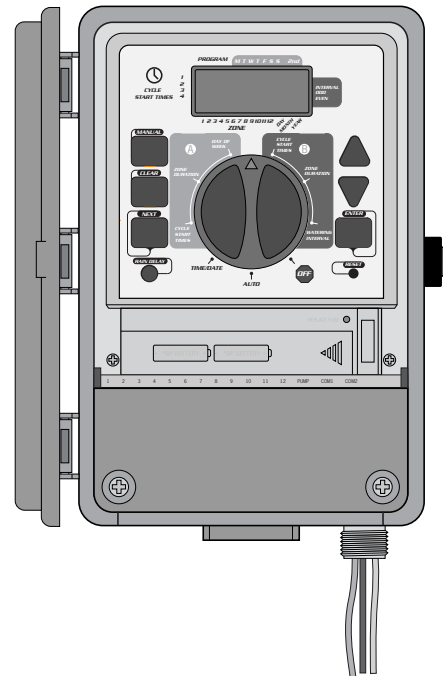

MODELS

57674, 57676, 57679, 57672,
57694, 57696, 57699, 57692,
57662, 57664, 57666, 57669,
57682, 57684, 57686, 57689,
57962, 57964, 57966, 57969,
57972, 57974, 57976, 57979,
94102, 94104, 94106, 94109,
94112, 94114, 94116, 94119

WT 12/13
versions

TABLE OF CONTENTS

ENGLISH

1 Introduction	1
2 Getting Started	2
3 Programming.....	3
4 Manual Operation	4
5 Installation of Indoor Mount Timer.....	6
6 Installation of Outdoor Mount Timer.....	7
7 Installing Valves, Pump Starts and Master Valves.....	8
Other Quality Products and Accessories.....	9
Trouble Shooting.....	10

FRANÇAIS

1 Introduction	11
2 Pour commencer	12
3 Programmation	13
4 Manuel d'utilisation	15
5 Installation du programmateur à montage intérieur	17
6 Installation du programmateur à montage extérieur	18
7 Installation des vannes, des relais de démarrage de pompe et des vannes principales	19
Autres produits et accessoires de qualité	20
Dépannage	21

ESPAÑOL

1 Introducción	22
2 Para comenzar.....	23
3 Programación	24
4 Operación manual.....	26
5 Instalación de un programador de montaje interior	27
6 Instalación de un programador de montaje exterior.....	28
7 Instalación de las válvulas, el encendido de la bomba y las válvulas principales.....	30
Otros productos y accesorios de calidad	31
Resolución de problemas.....	32

ITALIANO

1 Introduzione	33
2 Preparazione per l'uso	34
3 Programmazione	35
4 Funzionamento manuale	37
5 Installazione del programmatore-montaggio interno	38
6 Installazione del programmatore-montaggio esterno	39
7 Installazione delle valvole, pompa d'avviamento o valvola principale	41
Altri prodotti ed accessori di qualità	42
Individuazione ed eliminazione delle anomalie	43

DEUTSCH

1 Einführung.....	44
2 Anfang.....	45
3 Programmierung	46
4 Manueller und halbautomatischer Betriebsablauf	47
5 Inneninstallation des Steuergerätes.....	49
6 Außeninstallation des Steuergerätes	50
7 Installation der Ventile, Pumpenanlasser und Hauptventile..	51
Sonstige Qualitätsprodukte und Zubehör.....	52
Fehlerbehebung	53

1 section

Introduction

Thank you for selecting an Orbit® sprinkler Timer. Orbit® designers have combined the simplicity of mechanical switches with the accuracy of digital electronics to give you a Timer that is both easy to program and extremely versatile. The Orbit® Timer provides convenience and flexibility, letting you run a fully automatic, semi-automatic, or a manual watering program for all your watering needs.

Please read this manual completely before you begin to program and use the controller. A few of the most notable design features include:

At-a-Glance Simplicity

By turning the rotary dial to one of nine settings you can review programming or easily make changes.

Arm Chair Programmable

By inserting two AA alkaline batteries you can program the Timer prior to installing it in its permanent location.

Fuse

Red flashing LED indicates blown fuse. The 0.75 amp slow-blow fuse provides circuit protection. For replacement, use WaterMaster 0.75 amp fuse or equivalent.

Lexan Language Covers

Available in English, French, Spanish, Italian, German.

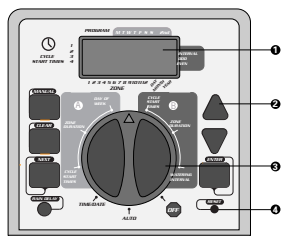

FIGURE 1: Location of Controls on the Timer

1. Digital Display

A large LCD (Liquid Crystal Display) shows the time of day and indicates many of the programming settings. The display is completely interactive with all other controls.

2. Programming Keys

The Timer has seven push button keys for setup and program entry. Working in conjunction with the rotary selector, the keys are used to set the time of day, watering time, watering days, start times, and other functions.

3. Selector Dial

This large dial makes it easy to see which function is currently selected and/or in which mode the Timer is set to operate.

4. Reset Button

The reset button clears the time, date and user-defined programming but does not remove the factory installed fail-safe program. To prevent an accidental reset, the button is recessed into the panel and must be pressed with a small pointed object such as a pen or pencil tip.

Notable Programming Features

Two Watering Programs—Summary

The Timer gives you the option of using one or both of the independent programs. Note that each station can independently be set to either A or B or both A and B programs.

Program—A

This program lets you schedule selected stations to water on specific days of the week or to water every 2nd day. Program A repeats itself continuously in successive weeks.

Program—B

Provides two options: One for odd or even day watering or for intervals ranging from everyday to every 28th day. This feature is designed to meet the growing needs and restrictions imposed by local governments and to conserve water. The Timer automatically calculates odd and even days (by date) for each month and makes adjustments for leap years to provide true odd and even watering through the year 2095.

Start-Time Stacking

The Timer has the intelligence to “stack” start times that overlap. If you enter two or more start times that overlap (in the same or in different programs), the Timer will not activate two stations at the same time. Instead, the Timer activates the first station and then activates the next station(s) in sequence after the first station finishes its preset watering duration. The Timer will NOT stack to the next calendar day. This prevents the Timer from violating an odd or even day watering schedule.

Manual and Semi-Automatic Modes

The Timer gives you a number of manual and semi-automatic modes for flexibility in watering. You can override the Timer’s automatic programming in a variety of ways.



Getting Started

Programming the Timer can be accomplished in just a few basic steps. Before you begin programming, it is important to install the battery, set the time of day and date, and establish a watering plan.

Install the Batteries

The Timer requires two AA batteries to maintain the time and date in case of AC power loss. In a typical installation, fully charged batteries should provide sufficient power for approximately three years of operation.

- Remove the terminal cover.
- Insert two AA batteries into the battery compartment.
- Return the terminal cover to its closed position.

Weak or missing batteries can cause the time and date to be erased after a power failure. If this happens, you will need to install fully charged batteries and re-enter the time and date. All other program settings will be maintained in non-volatile memory. The display will show "LO BAT" when it is time to replace the battery.

Set the Time of Day and Date

If this is the first time the Timer has been programmed, you should press the small recessed button labeled **RESET**. Pressing **RESET** does not affect the factory installed fail-safe program [See Figure 2].

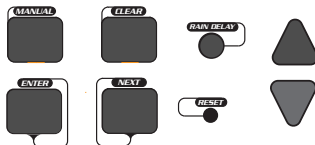

FIGURE 2: Programming Keys

- Turn the rotary dial to the **TIME/DATE** position [See Figure 3].
- **12:00 AM** will appear in the display with three arrows pointing to the year, month, and day.
- Use the **+** and **-** keys to set the correct time of day. When the correct time of day is reached, press the **ENTER** key to lock in the time. To increase or decrease more rapidly, hold down either the **+** or **-** keys until the display goes into rapid advance mode.
- A blinking cursor will appear below the arrow for the year, month, and date when programming [See Figure 4].
- Use the **+** and **-** keys to set the correct year, then press **ENTER**.
- Use the **+** and **-** keys to set the correct month, then press **ENTER**.
- Use the **+** and **-** keys to set the correct date, then press **ENTER**.



FIGURE 3: LCD Display with Surrounding Information

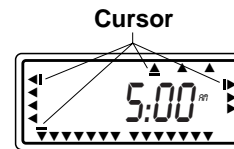

FIGURE 4

Caution: If a watering schedule is not entered into the Timer, the factory installed fail-safe program will turn on each station every day for 10 minutes. To avoid accidental valve activation, either turn the rotary dial to **OFF** or enter a watering schedule.

Establish a Watering Schedule

To help you visualize how best to program the Timer, it might be helpful to make a watering plan on paper. This will help you establish which days and times you want to water.



Programming

The Timer has two programs you can setup to control a variety of watering schedules. Depending on your needs, you can use either or both programs.

Enter the Watering Schedule in Any Order

You have the option of entering your watering schedule in whatever order you like. This feature makes it very easy to review and change your watering schedule. Your settings can be changed at any time—while you're setting up the initial schedule or even after years of operation.

Start Times for Program A or B

Note: A start time is the time of day that the program begins watering the first station, and all other stations in the program will then follow in sequence. There are not separate start times for each station. Start times do not correspond to specific stations, but to programs (A or B). If you enter more than one start time, all stations in the specified program will water again (in sequence).

- The way you set the cycle start time is the same for both programs. Turn the rotary dial to the **CYCLE START TIMES** position in the program that you want to set. The display will show an A or B depending on which program you have selected. The display will show ____ : ____ and a blinking cursor in **CYCLE START 1** location [See Figure 5].
- Set the time you want to begin watering for start time 1 using the **+** or **-** keys, then press the **ENTER** key. The display will advance to **START 2**. For additional start times, simply repeat this procedure by using the **+** and **-** keys to enter the time and then press **ENTER**. Remember, *Each start time will activate all stations that are set to water in the specified program. There are not separate start times for each station. Start times do not correspond to specific stations.*
- Up to four start times can be entered per program (A or B).

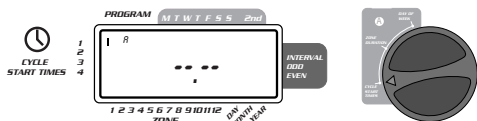

FIGURE 5: LCD Display with Start Time

Water Duration for Program A or B

Note: Both programs require watering durations to be programmed.

- Turn the rotary dial to **ZONE DURATION** position in either the A or B program.

The display will show which program you have selected with an "A" or "B" and the - - cursor blinking at station "1" [See Figure 6].



FIGURE 6: Station Duration for Program A

- You can set the watering duration from 1 to 99 minutes. Press and hold the **+** key to advance the number of minutes, or use the **-** key to go in reverse, then press **ENTER**. When the minutes are set, "A" or "B" will appear over station 1 and the cursor will advance to station 2 and begin blinking.
- Simply repeat these steps to set watering durations for all zones on this program
- To skip a station, press the **NEXT** key.
- To erase previously programmed watering durations, press the **CLEAR** key.

Assigning Watering Days for Program A

- Turn the rotary dial to **DAY OF WEEK** in program A. The display will show an "A" and the cursor will blink under the days of week **M, T, W, T, F, S, S** (Monday, Tuesday, etc.) [See Figure 7].

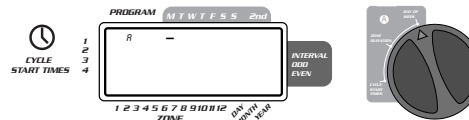

FIGURE 7: LCD Display with Watering Days

- Press **ENTER** to activate watering on Monday. An arrow appears under M and the cursor will advance to Tuesday ("T"), press **ENTER** to activate watering on this day. Repeat these steps for all days of the week.
- To skip a day, press **NEXT**.
- To delete a previously entered day, press **CLEAR**
- If you want to water every second day, press the **NEXT** key to advance the cursor to "2nd", then press **ENTER**.

Note: If you choose to water every 2nd day, you cannot set specific days of the week for watering

Assigning Watering Intervals for Program B

Program B is used to water at specific intervals between days (1 to 28), or on odd or even calendar dates. The Timer has a leap-year compensator and will ensure conformance to the odd and even schedule through the year 2100.

- Turn the rotary dial to **WATERING INTERVAL**. The cursor will blink to the left of the word **INTERVAL** [See Figure 8].

ENGLISH

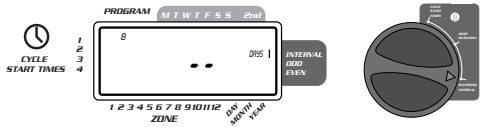

FIGURE 8: LCD Display with Watering Interval

- Press and hold the **+** or **-** keys to select the number of days between watering. **Example:** If you want to water once every 10 days, set the interval at 10.
 - To activate the watering interval, press **ENTER**.
- Note: If an interval of "3" is entered today, the Timer will water for the first time today, and then again every "3" days.*
- To select odd or even day watering, press **NEXT**. The cursor will move to either the odd or even setting, then press **ENTER**.
 - To erase a schedule, press **CLEAR**. To enter a new schedule, press **NEXT**.

Reviewing and Changing Your Program

The Orbit Timer lets you easily review a complete watering plan. For example, to review Program-A watering start times, simply turn the rotary dial to the **CYCLE START TIMES** position in Program-A and check the times that have been entered. Using the **NEXT** key, you can advance through the schedule without fear of disturbing any programming. If you want to change the start times, watering days, or interval, simply follow the directions for that program. After reviewing or changing a watering schedule, remember to turn the rotary dial back to **AUTO**.

Ready for Automatic Operation

After programming is complete, turn the rotary dial to **AUTO** [See Figure 9]. The Timer is now fully programmed and ready to use in the automatic mode. In automatic mode, each program will operate sequentially, starting with Program-A.

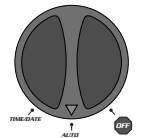

FIGURE 9: Ready for Automatic Operation

4 section

Semi-Automatic & Manual Operation

The Orbit Timer has the ability to override the automatic program without disturbing the preset program.

Using the Semi-Automatic Mode

(All stations cycle once both A & B programs)

- Turn the rotary dial to **AUTO**, then press the **MANUAL** key. The display will show **"AB"**, **"MANUAL"**, and **"ALL"** will be blinking [See Figure 10]. This indicates all stations will semi-automatically water for their assigned durations in sequence.
- To activate the **assigned** water durations in the A and B programs for each station, press **ENTER**.

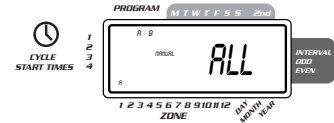

FIGURE 10: Semi-Automatic Watering for Stations Assigned to A and B Programs

Note: Water durations assigned to station 1 in program A will water first, then move to station 1 in program B before advancing to the second station and will continue alternating. Only those stations assigned a watering duration will water when using the manual or semi-automatic mode [See Figure 11].

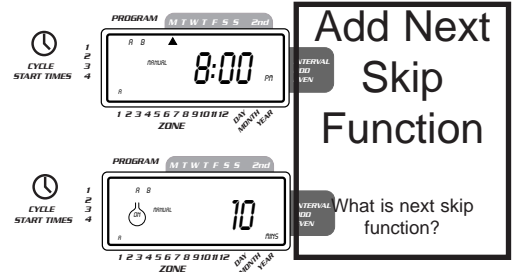

FIGURE 11: Semi-Automatic Watering Entered for A and B Programs, All Stations

(All stations cycle once, A program only)

- To activate each stations assigned watering durations for the A program **only**, press the **MANUAL** key, followed by the **NEXT** key. This will activate stations with assigned watering durations in the A program only. To initiate this

semi-automatic watering, press **ENTER** [See Figure 12].
(All stations cycle once, B program only)

- To activate each station assigned watering durations for the B program only, press the **MANUAL** key, followed by pressing the **NEXT** key two distinct times. This will activate only those stations with assigned watering durations in the B program only. To initiate this semi-automatic watering, press **ENTER**.

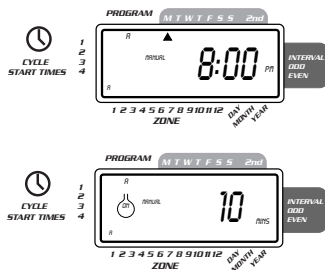

FIGURE 12: Manual Watering in Either the A or B Program Only

Using Manual Operation

The manual operation mode allows you to set durations in any of the stations from 1 to 99 minutes.

- Turn the rotary dial to **AUTO**.
- Press the **MANUAL** key. Then press **NEXT** three times. The display will show a blinking cursor on station 1 along with **-- MINS** [See Figure 13].

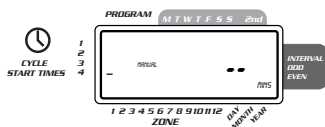

FIGURE 13

- To set the number of minutes for watering duration, press and hold the **+** key to advance to desired number of watering minutes. Use the **-** key to go in reverse. Press **ENTER** to begin watering.
- To skip a station, press **NEXT** until the cursor is blinking over the station number you wish to program. Example: To set station 3 for five minutes, press the **MANUAL** key; then press the **NEXT** key five times to select the manual operation mode and advance to watering for station 3; using the **+** or **-** key, set the manual watering duration to five minutes; then press **ENTER** [See Figure 14].

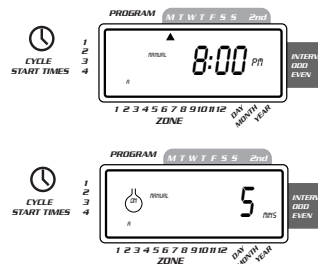

FIGURE 14: Manual Watering Station 3 for Five Minutes

Note: After the **MANUAL** key has been pushed, if a selection is not made within 60 seconds the display returns to the time of day.

- To halt or discontinue semi-automatic or manual watering, press the **CLEAR** key once. The Timer will revert to your original automatic watering plan.

Using the User Selectable Rain Delay Mode

To stop automatic watering for 24, 48, or 72 hours, use the **RAIN DELAY** mode key.

- With the rotary dial set to **AUTO**, press the **RAIN DELAY** key once then press **ENTER**. The Timer will force a 24-hour interruption of all scheduled watering. After 24 hours, the Timer will automatically return to its initial watering schedule.
- To increase the rain delay to 48 or 72 hours simply press the **RAIN DELAY** key again until the desired delay time is displayed, then press **ENTER**.
- To cancel the rain delay mode, press **CLEAR** [See Figure 15].
- Note:* While in rain delay mode, the timer will display the remaining hours (counting down) to the end of the accepted delay alternating with the current time and date. No other key besides **CLEAR** is accepted while the Timer is in the rain delay mode.

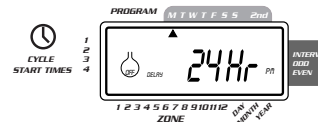

FIGURE 15: Display Showing Rain Delay

Complete System Shut Down

To shut the system down, turn the rotary dial to the **OFF** position. The Timer remains programmed but will not water.



Installation of Indoor Mount Timer

Install the controller in 4 easy steps—

1. Choosing a Timer Location
2. Mounting the Timer
3. Connecting the Transformer
4. Connecting Valve Wires to Timer

1. Choosing a Timer Location

- Select a location near a standard electrical outlet. Avoid using an outlet controlled by an **ON/OFF** switch.
- The timer should not be exposed to the weather or operate at temperatures below 14 degrees or above 113 degrees Fahrenheit (-10 to 45 degrees Celsius). Avoid direct sunlight. For use under “normal pollution conditions”.
- Installation works best in a garage or protected area. The timer should not be mounted outdoors.

2. Mounting the Timer

- A mounting template is provided to assist you in mounting the timer.
- Screw a No. 8 screw at eye level leaving the screw head extended out from the wall about 1/8 inch. Use expanding anchors in plaster or masonry if necessary.
- Slip the keyhole slot in the back of the timer over the extended screw.
- Screw a No. 8 screw through each of the two holes at the bottom of the box into the wall [See Figure 16].

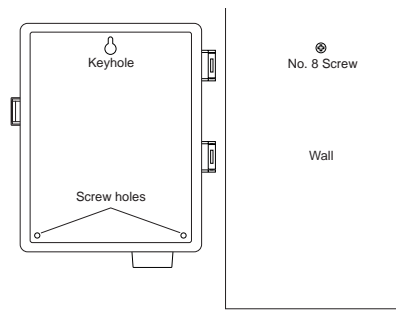

FIGURE 16: Mounting of an Indoor Timer

3. Connecting the Transformer

- With the wiring terminal shroud off, find the two terminal holes labeled “24 VAC.” Make sure the transformer is not plugged in. Insert one of the two power leads from the transformer into each terminal. It doesn't matter which lead goes into which terminal.
 - It may be necessary to open the terminal to allow for wire insertion or removal. To do this, simply press upward on the tab located on top of the terminal [See Figure 17].
 - Plug in the transformer
- Warning:** Do not link two or more controllers together with one transformer.
- Slide the shroud back on.

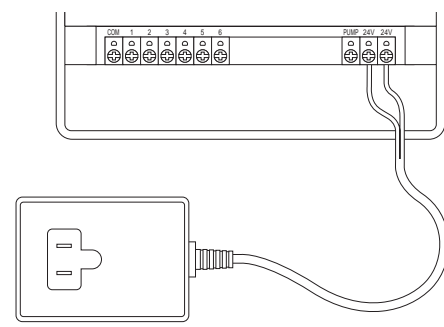

FIGURE 17: Connecting Transformer

Precautions:

- This controller is not intended for use by young children or infirm persons without supervision.
- Young children should be supervised to ensure they do not play with the controller.

section Installation of Weather-Resistant Indoor-Outdoor Controllers

All our Weather-resistant Indoor/Outdoor controllers can run at temperatures between 35 and 140 degrees Fahrenheit (0 to 60degrees Celsius). Storage temperature is -4 to 149F (-20 to 65C).

Direct sunlight can easily increase temperatures inside the Controllers so chose a shaded location.

The controllers are weather-resistant to UL-50 and ETL® Listed, but should not be placed in areas where continuous water could cause damage.

Caution: Do not open the Controller when it is raining.

To make installation easier the Controller has a removable door. Remember to leave at least 7ins (18cm) to the left of the controller box for the door to swing open after installation.

Check the model number of your timer: various models are configured differently to meet national requirements, look for the section covering the model number on your controller. The model number can be found on the back of the housing, together with other useful information.

Models 57694, 57696, 57699, 57692

are for installation in Australia, New Zealand, and South Africa using the fitted line cord.

Models 57974, 57976, 57979, 57972

are for 110/117VAC operation and are suitable for either wall-hanging installation using the line cord fitted or permanent installation. You need to decide which type of installation you are going to use. Ensure that you have the appropriate electrical power available at the location you intend to use. If used outdoors with the line cord, a suitable weatherproof power outlet must be available.

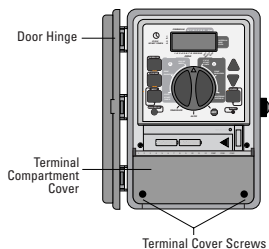

FIGURE 18: Outdoor Timer, Showing Terminal Cover

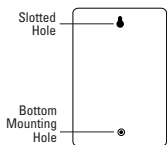

FIGURE 19: Back of Timer Box

Installation using the fitted line cord

- Use the mounting template provided to assist you in preparing the mounting location: choose a flat, clean surface.
- Using the upper mark on the template, insert a No. 8 screw (included) at eye level leaving the screw head about 1/8th inch (3mm) out from the wall. (Use

7

expanding anchors in plaster or masonry if necessary).

- Using the lower mark on the template, affix a No. 8 screw (included), again leaving the head protruding.
- Slip the slotted keyhole in the back of the Controller over the extended upper screw and allow the lower screw to recess into the lower hole in order to prevent the Controller from swinging. [See Fig.19].
- The line cord may now be inserted into the power outlet.
- Proceed to section 7.

Installation using permanent wiring

Preparing the Controller for Permanent Installation

Before commencing to install the controller you must remove the fitted line cord and replace with the pigtail wires provided.

- Take off the terminal compartment cover by unscrewing the two screws and pulling the plastic cover forward. [See figure 18], this reveals the AC Power Cover [Figure 21].
 - Remove the rubber weather plug from the hole in the center and unscrew the one fixing screw, pull the plastic cover forward to reveal the AC wiring.
 - Use a punch to create a hole in the blind Bottom Mounting Hole on the back of the controller box [Figure 19: Bottom Mounting Hole].
 - Loosen the screw on the cord restraint and the three screws on the terminal block and remove the line cord completely.
 - Feed the three wires of the pigtail through the exit nipple, under the strain relief, and cross to the terminal block. Fasten the wires to the terminal block ensuring that the black wire is connected to the Live terminal marked L, the white wire is connected to the Neutral terminal marked N, and the green wire is connected to the Earth terminal marked E. Ensure that the terminal screws and the strain relief screw are all firmly tightened. Check that the wires are clear of any obstruction and will not be trapped by the AC Power Cover when it is replaced.
 - Replace the AC Power Cover and screw tight, do not force into place, if resistance is met check that no wires are trapped.
- The Controller is now ready for permanent installation; follow all the instructions for the following models to complete the installation. (use expanding anchors in plaster or masonry if necessary).

Models 57684, 57686, 57689, 57682

International Models 94114, 94116, 94119, 94112

All the above listed models are designed for permanent installation only. Local building and electrical codes usually require that an approved electrical conduit and electrical fittings be used to connect exterior wall-mounted equipment to AC power. Please check local codes. Any permanent connection should be made by a licensed electrical contractor in accordance with the requirements of the National Electrical Code and other state and local codes.

- Take off the terminal compartment cover of the controller by unscrewing the two screws and pulling the plastic cover forward. [Figure 18].
- Remove the rubber weather plug from the screw hole.
- Use the mounting template provided to assist you in preparing the mounting location: choose a flat, clean surface.

- Using the upper mark on the template, insert a No. 8 screw (included) at eye level leaving the screw head about 1/8th inch (3mm) out from the wall. (Use expanding anchors in plaster or masonry if necessary).
- Slip the slotted keyhole in the back of the controller box over the extended screw [Figure 19].
- Push a No. 8 screw (included) through the Bottom Mounting Hole [Figure 19] in the controller box and tighten until the box is held firmly to the wall, but do not over-tighten.

The Controller has separate compartments for the AC line power input and the low voltage outputs. You must keep the input power and the low voltage in their separate places when wiring the controller box.

The controller has a built in transformer that must be connected to an AC line voltage source. Check the back of the controller box for power requirements. This connection should be made by a licensed electrical contractor in accordance with the requirements of the National Electrical Code and other state and local codes.

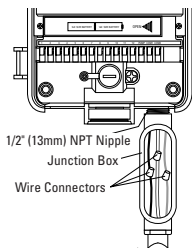

FIGURE 21: AC Wiring Using Junction Box

Wiring the AC input

Caution: do not connect the controller to one phase of a three-phase power system used by a pump or other electrical equipment.

The controller has a standard electrical power connection [Figure 21]. Use this 1/2 inch (13mm) NPT nipple to connect the controller to a standard electrical junction box that should be UL Listed (or equivalent) or comply with IEC or EN standards (or equivalent).

- Turn off the AC power at the AC circuit breaker and apply an appropriate safety lockout. Verify that the power has been turned off to the installation site using an AC voltmeter set for the correct measurement range.
- Use power feed wire of 14 gauge (AWG) minimum with a temperature rating of 155 degrees Fahrenheit (68 degrees Celsius) or higher.
- Install the conduit and associated fittings. Connect the AC electrical power wiring to the source by following all the right codes and local standards.
- Connect the junction box (not included) to the NPT nipple [Figure 21].
- Connect the source power conduit to the entrance of the junction box, following all the appropriate codes.
- Connect the source wires to the wires extending from the controller. Take care to follow the correct color code. For USA: connect the Green for Ground, Black for Live, and White for Neutral. Often the source ground may be bare copper conductor rather than green wire. For Europe: Live is Brown and Neutral is Blue, there is no ground connection required. Be sure that all wires are connected to the proper source wire.
- Make sure all connections are made with code-approved insulated connectors.
- Be sure to place a weatherproof gasket and lid on the junction box.

7 section

Installing Valves, Pump Start Relays & Master Valves

1. Wiring the Electric Valves

- If the distance between the controller and valves is under 700 feet (210 m), use WaterMaster® sprinkler wire or 20 gauge (AWG) plastic jacketed thermostat wire to connect the controller to the valves. If the distance is over 700 feet (210 m), use 16 gauge (AWG) wire. Terminals accept up to 14 gauge wire. The wire can be buried in the ground; however, for more protection wires can be pulled through conduit and buried underground. Be careful to avoid burying the wires in locations where they could be damaged by digging or trenching in the future.

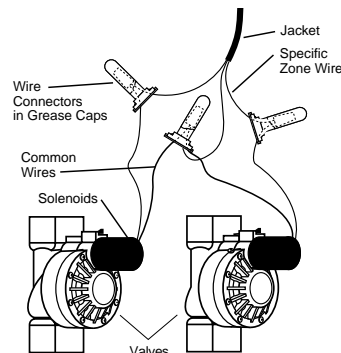

FIGURE 22: Connecting Timer Wires to Valves

- Each valve has two wires. One wire is to be connected as the common. The common wires for all the valves can be connected together to one common wire going to the timer. The other valve wire is to be connected to the specific station wire that will control that valve [See Figure 22].
 - All wires should be joined together using wire nuts, solder, and/or vinyl tape. For additional protection to waterproof connections, a WaterMaster® grease cap can be used.
 - To avoid electrical hazards, only one valve should be connected to each station.
- ### 2. Connecting Valve Wires to the Timer
- Remove the terminal compartment cover.
 - Strip 1/4" (6 mm) of the plastic insulation off the end of each wire.
 - Determine which valve you want to connect to which station. Connect

- each valve wire to its station terminal (labeled 1-12) by inserting the bare wire fully into the terminal.
- It may be necessary to open the terminal to allow for wire insertion or removal. To do this, simply press upward on the tab located on top of the terminal [See Figure 23].
 - Connect the common wire to the terminal labeled **COM** [See Figure 23].

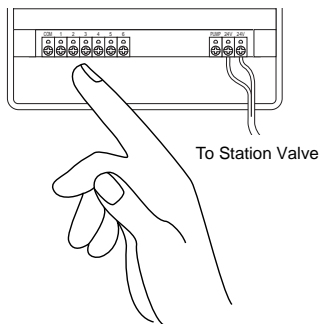

FIGURE 23: Connecting Valve Wires

*Note: Only one wire can be installed into each terminal. If more than two common wires are used in your system, splice several together so only one wire runs into each of the **COM** terminals. Protect the splice connection with a wire nut.*

Australian Rating Information

Transformer:

Output: 600 mA 24 VAC 50 Hz
 Input: 240 VAC 50 Hz

Controller Output:

24 VAC

OTHER QUALITY PRODUCTS AND ACCESSORIES

Automatic Rain Shut-Off

For automatic rain shut-off, contact your Orbit® dealer to purchase an Orbit® Model 57091 (94060) automatic rain shut-off switch. The rain shut-off easily connects to the timer and prevents overwatering during rainy periods.

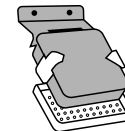

Weather Resistant Timer Box

Allows outdoor installation of most brands of indoor mount timers. UL® listed.

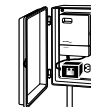

Automatic Valves

Durable, non-corrosive plastic construction. Automatic valves are available in anti-siphon or straight valves with safe, low voltage.

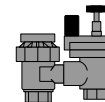

Automatic Converters

Durable non-corrosive plastic construction. Converts most brands of plastic or brass valves to automatic.

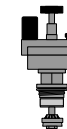

Grease Caps

Protects low voltage wires from corrosion or shorts.



Remote Control Transmitter and Receiver

Control your sprinklers with the touch of a button up to 200' (60 m) from your sprinkler controller.

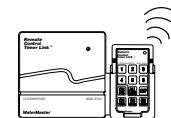

TROUBLESHOOTING

Possible Causes of Problems

One or more stations do not turn on:

1. Faulty solenoid.
2. Wire broken or not connected.
3. Flow control stem screwed down, shutting valve off.
4. Programming is incorrect.

Stations turn on when they are not supposed to:

1. Water pressure is too high.
2. More than one start time is programmed.

One station is stuck on and will not shut off:

1. Faulty valve.
2. Particles of dirt or debris stuck in valve.
3. Valve diaphragm faulty.

All stations do not turn on:

1. Transformer defective or not connected.
2. Programming is incorrect.
3. Fuse has been blown.

Controller will not power up:

1. Fuse has been blown.
2. Transformer not plugged into an operational AC outlet.

Stations continue to turn on and off when they are not programmed to:

1. More than one start time is programmed with overlapping schedules.
2. Excessive pressure.

Fuse blows repeatedly:

1. Short in wiring or solenoids.

Help

Before returning this timer to the store, contact Orbit® Technical Service at: **1-800-488-6156**.

Listings

The timer is tested to UL-1951 (Indoor models) and UL-50 (outdoor models) standard and is ETL® listed. Appropriate international models are CSA® and CE® approved.

Trademark Notice

WaterMaster® is registered trademark of Orbit® Irrigation Products, Inc.

The information in this manual is primarily intended for the user who will establish a watering schedule and enter that schedule into the timer. This product is intended to be used as an automatic timer for activating 24 VAC irrigation valves, as described in this manual.

WaterMaster® by Orbit® Limited Four Year Warranty

Orbit® Irrigation Products, Inc. warrants to its customers that its WaterMaster® products will be free from defects in materials and workmanship for a period of four years from the date of purchase. We will replace, free of charge, the defective part or parts found to be defective under normal use and service for a period of up to four years after purchase (proof of purchase required). We reserve the right to inspect the defective part prior to replacement. Orbit® Irrigation Products, Inc. will not be responsible for consequential or incidental cost or damage caused by the product failure. Orbit® liability under this warranty is limited solely to the replacement or repair of defective parts.

To exercise your warranty, return the unit to your dealer with a copy of the sales receipt.



1-800-488-6156
1-801-299-5555
www.orbitonline.com

Orbit® Irrigation Products Inc.
845 North Overland Rd.
North Salt Lake, Utah 84054

57962-24 Rev G